

**GENERAL ATOMICS ENERGY PRODUCTS**  
*Engineering Bulletin*

**A THREE-LEVEL DC-DC  
CONVERTER WITH WIDE-INPUT  
VOLTAGE OPERATIONS FOR  
SHIP-ELECTRIC-POWER-  
DISTRIBUTION SYSTEMS**

**Byeong-Mun Song, Robert McDowell, and Andy Bushnell**

**Presented at:**

**IEEE Pulsed Power Conference  
June 2003**

© 2003 IEEE

 **GENERAL ATOMICS**  
**Energy Products**  
**SORRENTO ELECTRONICS**  
4949 GREENCRAIG LN, SAN DIEGO, CA 92123-1506  
858.522.8400

# A Three-Level DC-DC Converter with Wide-Input Voltage Operations for Ship-Electric-Power-Distribution Systems

Byeong-Mun Song, Robert McDowell, and Andy Bushnell

General Atomic Energy Products  
Sorrento Electronics, Inc.

4949 Greencraig Lane, San Diego, CA 92123 USA

Email: [byeong-mun.song@sorrento.com](mailto:byeong-mun.song@sorrento.com), [www.gaep.com](http://www.gaep.com)

**Abstract:** This paper describes a newly developed 3-level dc-dc converter with wide-input voltage operations for ship-electric-power-distribution systems. The proposed converter is designed with zero-voltage-switching (ZVS) techniques. The operational principles, designs details and performance of the converter are discussed along with soft-switching characteristics and load transients through experimental waveforms. The converter achieved about 95% efficiency over wide 7kW load conditions.

**Index Terms:** 3-Level dc-dc converter, ZVS converter, dc power supply, soft-switching converter.

## I. INTRODUCTION

With advanced power electronics technologies, there has been a growing interest in high voltage converters for zonal ship-electric-power-distribution systems. There are significant challenges to improve overall efficiency of the converter; resulting in reduction of size and cost. The converter as part of the house keeping power supply is required to provide power to vital loads. This provides uninterrupted power to mission-critical loads to allow the ship to “fight through” a damage situation. The 7kW converter generates a nominal dc output voltage of 68V for wide-input voltage range from 850VDC to 1,250VDC. The converter should internally provide protection against reverse power flow and will be hot swappable. In addition, the design life of the converter reflects a naval ship design life of 30 years along with 95% efficiency.

To obtain a solution that provides enough power and meets the size, weight, and protection constraints, the converter topology should be carefully selected to meet these requirements. There are many candidate topologies available for high performance dc-dc power conversions [1-4]. These structures are quite different, depending upon the use of voltage clamping methods. Among them, recent zero-voltage-switching (ZVS) 3-level dc-dc converters are widely used for step-down dc-dc converter applications [5-7].

In this paper, a half-bridge zero-voltage-switching (ZVS) 3-level dc-dc converter with flying capacitors was developed for a 7kW house-keeping power supply. The converter circuit is described herein with operational principle, practical

design details, and various tests results. In addition, the overall performance of the converter is presented.

## II. DESIGN REQUIREMENTS

### A. Design requirements

In ship electric power distribution systems, the main electrical requirements of a 7kW dc-dc converter are determined by system requirements. Table 1 summarizes the electrical input and output design requirements.

Table 1. Input and output requirements.

Input/output characteristic	Requirement
Input voltage range	850 to 1,250 VDC
Input voltage ripple	25 V <sub>p-p</sub>
Nominal output voltage	68 VDC
Output voltage ripple	< 2%
Output voltage regulation	< 5%
Output power	7 kW
Efficiency from half to full load	> 95 %
High voltage isolation	> 10MΩ @ 1,500VDC
Output voltage isolation	> 10MΩ @ 600 VDC

As well as electrical design requirements, other design considerations must be applied to the converter:

- Relay isolation at the high voltage DC input bus,
- Diode isolation at the low voltage DC output bus to prevent reverse power flow,
- Size limitation to 19” × 20” × 7” cabinet module,
- Parallel operation for hot swapping,
- Status functions, and
- DOD specification requirements to EMI, shock and vibration, etc.

### B. Conceptual targets

As mentioned in the design requirements above, the design goals of the converter give us technical challenges including:

- Wide voltage range from 850 to 1,250VDC,
- Low voltage ripple of 25V<sub>p-p</sub>,
- High voltage conversion ratio, nominal 1,000V vs. 68V, but worse in reality at 1,250V<sub>max</sub>,

- High efficiency greater than 95%, and
- Limited low-voltage high-current devices available.

There is no benchmark circuit available for such an application. Along with these challenges, the converter must be designed to meet the specification requirements. To satisfy all requirements, the major design rules are applied to this converter as follows:

- Selection of highly efficient converter topology,
- Use of lowest turn-on resistance MOSFETs, which can be found in a SOT-227 package,
- SOT-227 Schottky diode module (150V-110A) in parallel to reduce the conduction loss,
- Compact packaging of the power components to minimize leakage inductance, and
- Use of laminated printed circuit board (PCB) bus bar power connection to serve as a high frequency DC link capacitor.

## II. ZVS 3-LEVEL DC-DC CONVETER

### A. Main circuit

Figure 1 shows a ZVS 3-level converter for 7kW dc power supplies. The converter consists of two power stages, high and low voltage. The high voltage stage is with four main switches, two blocking diodes and a flying capacitor to ensure the voltage sharing across the blocking switches. It is possible to allow the operation of the converter with a phase-shifting control, so that the converter can achieve soft switching for the inner switches of  $S_2$  and  $S_3$  by using the leakage inductance in the transformer. The low voltage stage is connected to the center-tapped windings of the transformer along with an output filter composed of  $L_o$  and  $C_o$ . And the blocking diode  $D_b$  is included to the load side to prevent reverse power flow. In the main circuit, the dc split capacitors  $C_1$  and  $C_2$  establish a voltage midpoint between 0 and the input dc voltage. The switch pairs,  $S_1$  and  $S_4$ , and  $S_2$  and  $S_3$ , are alternately turned on and off for a given interval.

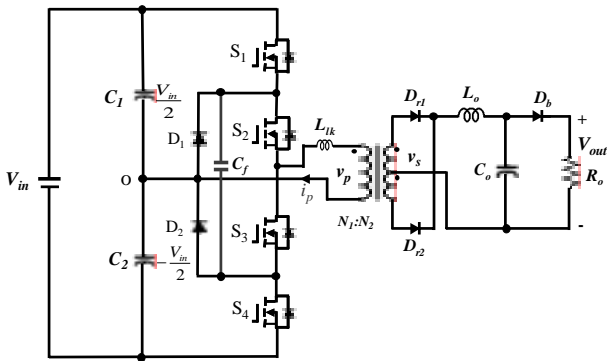

Figure 1. ZVS 3-level dc-dc converter for dc power supplies.

With bi-directional current paths, the flying capacitor should be charged or discharged depends on the voltage

conditions to make the voltage balance between the switching cells. The balanced voltage serves as the blocking voltage of  $S_2$  and  $S_3$  at turnoff, and provides a solution for the unbalancing problem between the dc split capacitors.

### B. Operational principle

Figure 2 shows the switching sequences of the converter, which has four different operational modes to achieve the desired output voltage waveforms at steady state operations.

1) *Mode I*: When  $S_1$  and  $S_3$  are conducting, the diode of  $D_1$  is blocking the current path and the output voltage becomes zero. If the flying capacitor voltage,  $v_{Cf}$ , is lower than the voltage across the dc split capacitor of  $C_1$ , the flying capacitor is charged through  $C_1 \rightarrow S_1 \rightarrow C_f \rightarrow D_2$ .

2) *Mode II*: When  $S_1$  and  $S_2$  are conducting, the current directly flows to the transformer and the output voltage of the transformer becomes  $V_s/2$ .

3) *Mode III*: In this mode,  $S_2$  and  $S_4$  are conducting. The current path is blocked by the diode of  $D_2$  and the output voltage becomes zero. Like Mode I, if the flying capacitor voltage,  $v_{Cf}$ , is lower than the voltage across the dc split capacitor of  $C_2$ , the flying capacitor is charged through  $C_2 \rightarrow D_1 \rightarrow C_f \rightarrow S_4$ .

4) *Mode IV*: When the top switch  $S_1$  and  $S_2$  are turned off and the bottom switch  $S_3$  and  $S_4$  are turned on, the voltage charged in  $C_2$  is used to provide power to the transformer. At this mode, since the voltage across the transformer feeds to the negative rail, the current path is negative and the output voltage becomes  $-V_s/2$ .

Considering wide-input voltage fluctuations, it is necessary to control the phase-shifting angle ( $\phi$ ) between phase legs. The angle as shown the second trace of Figure 2 is set at the maximum input voltage.

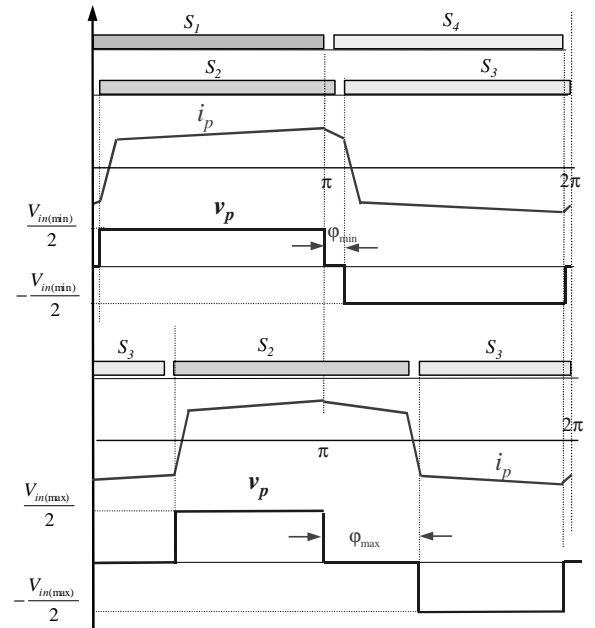

Figure 2. Voltage and current waveforms of the converter.

### III. TEST RESULTS

In order to verify performances of the proposed converter, tests were conducted of a 7kW dc-dc converter. The main components of the converter are:

- $S_1 - S_4$  : 44A/800V(APT8015JVFR)
- $C_f$  : 3 $\mu$ F/800V
- $D_1 - D_2$  : 30A/1,000V (APT30D100BHB)
- $C_1 - C_2$  : 130 $\mu$ F/800V
- $L_{lk}$  : 10 $\mu$ H (internal leakage inductance)
- $D_{r1} - D_{r2}$  : 200A/400V (HFA200MD40C)
- $L_O$  : 6.8 $\mu$ H
- $C_O$  : 32,000 $\mu$ F/100V
- $D_b$  : 2\*110A/150V (APT2 $\times$ 100D20J)

The transformer was designed for a high switching frequency of 80kHz. The main parameters follow as:

- Turn ratio :  $N_1 = 20$  and  $N_2 = 5$
- Core area : 15.7 cm<sup>2</sup> (effective)
- Core size : E 100/28 \*4 sets

Figure 3 shows photographs of the 7kW dc-dc converter. A 3-layer PCB as shown in Figure 3(a) holds the dc bus capacitors and is mounted on top of the main switches to reduce the parasitic inductance as much as possible. The physical size of the heatsink is designed with 2.5”(H)  $\times$  4”(W)  $\times$  3”(L). Figure 3(b) shows the overall of the converter for 7kW electric power distribution systems.

Figure 4 shows the experimental voltage and current waveforms in the primary side of the transformer at 1,100 VDC input. It can be seen that the primary power is transferred to the output side without any voltage spikes during switching. The voltage is well balanced between switching cells. At the maximum input voltage of 1,250V, the phasing-shifting time between cells is limited to 2.6 $\mu$ s. The phase-shifting time at 1,100V input was 2.4 $\mu$ s as shown in the top trace of Figure 4. Experimentally obtained waveform was 7kW for the output power, and 15A for the primary peak current.

Figure 5 shows the experimental waveforms of the drain-to-source voltage,  $V_{S2(D-S)}$ , gate-to-source voltage,  $V_{S2(G-S)}$  and primary current,  $I_p$ . During turn-on, when  $V_{S2(D-S)}$  reaches zero,  $V_{S2(G-S)}$  is turned on at the zero voltage condition. Thus, the ZVS was demonstrated in this experiment. ZVS effectively eliminates the turn-on switching losses.

Figure 6 shows the output voltage waveforms of the converter under load transients. When the load changes from 100% to 50%, the output voltage as shown in Figure 6(a) is followed by the controller, and the voltage variation was within 1.8V peak during 5ms, 2.6% of  $V_{out}$ . Figure 6(b) shows that the output voltage also tracks the load step change when the load changes from 50% to 100%. The step response time is 3ms and the voltage overshoot is within 2.5V, 3.6% of  $V_{out}$ . These results satisfied the specification of 5% regulation while the load is stepped from 50% to 100% and back to

50%. The transient response magnitude can be reduced if additional capacitors are installed at the output of the converter, but the settling time would be increased.

Figure 7 shows the experimental measured efficiencies of the converter under different dead times. With  $t_d = 430$ ns, the efficiency of the converter is 95.5% at full load condition, and 95.7% at 50% load. The efficiency includes all power converter module components, and behaves as shown in Figure 7. As shown, at light load region, a large dead time like  $t_d = 500$ ns results in a better efficiency of the converter.

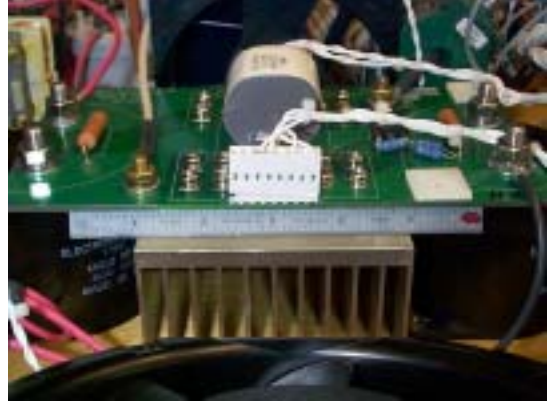

(a) Photograph showing a power stage with 3-layer printed circuit.



(b) Overall view

Figure 3. Photographs showing a 7kW dc-dc converter

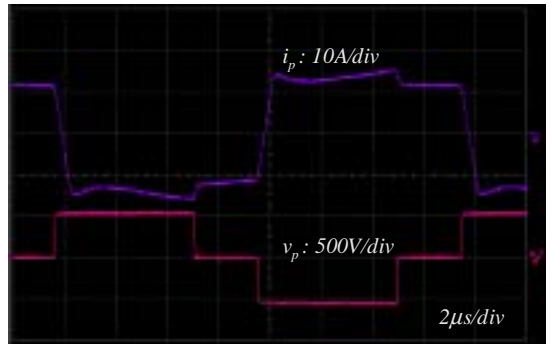

Figure 4. Primary current and voltage waveforms of the transformer.

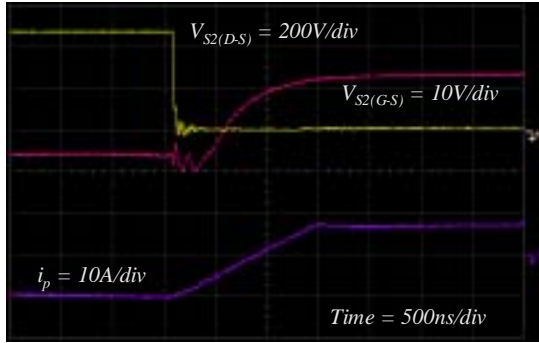
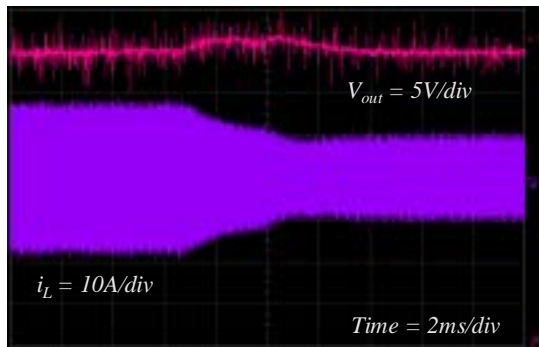
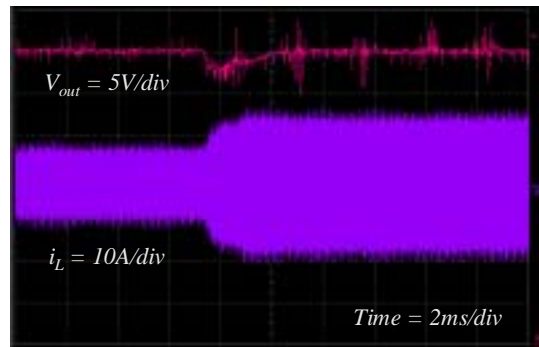

Figure 5. Zero voltage switching waveforms of  $S_2$  during turn-on.



(a) Load change from 100% to 50%



(b) Load change from 50% to 100%

Figure 6. Load transient characteristics of the converter.

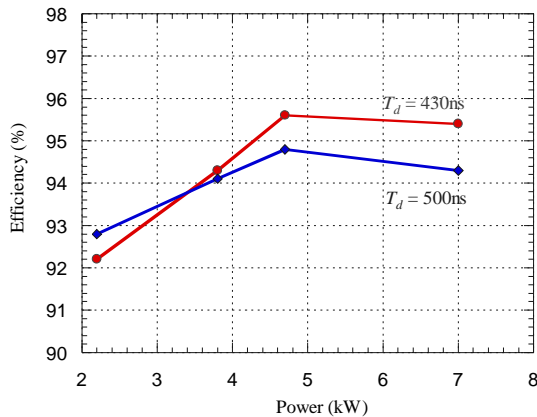

Figure 7. Efficiencies of the converter under different loads.

## IV. CONCLUSION

A newly developed ZVS 3-level dc-dc converter with wide-input voltage operations for ship-electric-power-distribution systems has been proposed and implemented. The operation of principles, designs details and test results were discussed with soft-switching characteristics and load transients. The converter has achieved nearly 96% efficiency by the significant reduction of the switching losses along with soft switching.

With the merits of simplicity and high efficiency, the proposed converter shows excellent performance and potential for various industry applications including telecommunication, aircraft, ship and medical power supply applications.

## REFERENCES

- 1) F. Canales, P. Barbosa, and F. C. Lee, "A Wide Input Voltage and Load Output Variations Fixed-Frequency ZVS DC/DC LLC Resonant Converter for High-Power Applications," in *Conf. Rec. of IEEE-IAS*, Oct. 2002, pp. 2306-2313.
- 2) J. S. Lai and F. Z. Peng, "Multilevel Converter – A New Breed of Power Converters," *IEEE Trans. on Ind. Appl.*, Vol. 32, No. 3, May 1996, pp. 509-517.
- 3) T. A. Meynard and H. Foch, "Multi-level Choppers for High Voltage Applications," *EPE Journal*, Vol. 2, No. 1, March 1992, pp. 45-50.
- 4) J. R. Pinheiro and I. Barbi, "The Three-Level ZVS PWM Converter – A New Concept in High-Voltage DC-TO-DC Conversion," in *Conf. Rec. of IEEE-IECON*, Nov. 1992, pp. 173-178.
- 5) F. Canales, P. Barbosa, and F. C. Lee, "A Zero-Voltage and Zero-current Switching Three-Level DC/DC Converter," *IEEE Transactions on Power Electronics*, Vol. 17, No. 6, Nov. 2002, pp. 898-904.
- 6) E. Deschamps and I. Barbi, "Flying-Capacitor ZVS PWM 1.5kW DC-to-DC Converter with Half of the Input Voltage Across the Switches," *IEEE Transactions on Power Electronics*, Vol. 15, No. 5, Sept. 2000, pp. 855-860.
- 7) X. Ruan, L. Zhou, and Y. Yan, "Soft-Switching PWM Three-Level Converters," *IEEE Transactions on Power Electronics*, Vol. 16, No. 5, Sept. 2001, pp. 612-622.