

REVISION LETTER	DATE	APPROVED	DESCRIPTION
A	04/10/02	JBE / JFB ECO: 18630	Original Creation & Release (30957 is 30937 w/different flying leads)
B	06/12/02	JFB ECO: 18682	Capture Red Lines Page 3: added AI-082 to Step 3.2. Page 6: added Winding Separator; Bottom Tab Insulation length changed from 3.75 to 3.5. Page 8: added 'Stamp ... positive bushing...'; removed '- PS' from Zoll pn on label.
C	06/21/02	JFB ECO: 18682	Page 3: Step 18.0 added 'Stamp Positive Bushing'. Page 4: changed MPPL from 10581-071 to 10581-112; Arbor Insert, Interleaf, Protective Wrap width changed from 2.75 to 2.95 (also on Page 6); Active length & Active Turns changed from 9582 & 2072 to 8639 & 1967, respectively; pad dimensions changed from 1.71 x 2.61 to 1.49 x 2.59. Page 5 adjusted program count for new length. Page 6: Bottom Spacer quantity changed from 2 to 1; Winding Separator length changed from 3.0 to 3.1. Page 8: Zoll pn on label changed rev A to rev B. BOM: 10581-071 changed to -112; 50057-381 changed to -390; 50057-382 changed to -391; 13658-001 quantity changed from 2 to 1; cable assy 98306-521 & -522 changed to -525 & -526; added 104109 shorting tab; 101323 changed to 50057-384. Page 6: can shrink sleeve length changed from 5.00 to 4.86.
D	07/31/02	JFB ECO: 18826	Page 4: Active Turns changed from 1967 ± 60 to 1932 ± 30; Roll Diameter changed from 2.285 - .065, +.025 to 2.17 ± 0.13; Pad thickness/width tolerance changed from ± .02/± .04 to ± .08/± 0.20, respectively; Active Width corrected from 2.46 to 2.66. Page 6: Bottom Tab Insulator length changed from 3.50 to 3.75; added Note 5. Page 8: Step 7 Max Cap Loss changed from 0.3 to 0.8 & DF Max Increase changed from .06 to 0.30; removed note about polarity stamping positive bushing.
E	09/06/02 ECO:	J.B. Ennis 18852	Page 5: Adjusted Hilton 9/6 Winding machine setup parameters. Page 5B: Added 8" Hilton End Winder setup page. BoM: Added Item 470, PN 104109 shorting connector for shipping.
F	01/20/03	JFB ECO: 18939	Page 3: Step 8 added AI-002; switched Steps 17.2 & 17.3; 17.4 added AI-091; Step 19 added AI-090. BOM: 101637, zn wire, quan changed from 0.17 to .08
G	01/27/03	JFB ECO: 18948	Pages 3 & 7: changed arc spray instruction from 'half-oval' to 'full end spray'. Change verified by life tests on EXP 491.
H	02/25/03	JFB ECO: 18974	BOM: added 11710-507 cover assy, rolled rivet.
J	05/16/03	JFB ECO: 20029	Pages 2, 3 & 8: changed designated oil from SO to RSO. Page 10: added soldering note. Page 5: revised program outputs & counts. BOM: added 101629 solder; replaced 100667 silicone oil with 100665 rapeseed oil. Page 3: removed bushing polarity stamping note.
K	08/01/03	JFB ECO: 20075	Page 4: Active Length changed from 8639 ± 432 to 8423 ± 210; Active Turns changed from 1932 to 1900. Page 3: added AI-092 to Step 4.0.
L	10/16/03	JFB ECO:	Page 3: changed process to add flying leads before acceptance tests followed by cup epoxy potting (previously both lead attachment & potting were done after testing.) Page 8: Steps 3 & 7 min DF changed from 0.10 to 0.25; Steps 4 & 8 min/max DF changed from 10/50 to 30/70 (changes to allow for measuring DF through flying leads.) Page 10: lead attachment scheme expanded to feeding wire through terminal hole, folding wire back & soldering & then bending terminal down with the use only of a special tool designed to set bend height.
M	12/15/03	JFB ECO: 20192	Page 3: Step 16 removed AI-022 from instructions; Step 18 changed AI-022 to AI-091. Page 6: Can Sleeve SubAssy fn 100 corrected to 430. Page 8: Zoll rev letter on label changed from B to C. Page 10: Steps 2 & 3: edited to have the terminal bent down first & then the wire soldered. BOM: Cover Assy -505 quantity changed from 1 to AR; Cover Assy -507 quantity changed from AR to 1. ALSO: Page 8: deleted delta DF (10kHz) limit (Steps 4 & 8); Pages 4 & 7: Dry Cap changed from 111.4 ± 5.6uF to 108.0 ± 5.4uF.

NOTE : ZOLL MEDICAL MUST BE NOTIFIED OF ALL DESIGN AND / OR PROCESS CHANGES AND PLANNED IMPLEMENTATION DATE CODES.

<p>Capacitor Model No. 30957 115.0 uF ± 5 % , 2.3 kV</p> <p><b>REVISION HISTORY</b></p> <p>VERSION: CS30000B</p>	<p>PROJECT MANAGER</p> <p>PROJECT ENGINEER J.B. Ennis</p> <p>APPROVED</p>	<p><b>SORRENTO ELECTRONICS</b></p> <p><b>GENERAL ATOMICS</b></p> <p>Energy Products 4949 GREENCRAIG LANE SAN DIEGO CA. 92123</p>			
	<p>APPROVED SAFETY</p> <p>APPROVED Q.A.</p> <p>CHECKED BY</p> <p>DRAWN BY J. B. Ennis</p>	<p>SIZE A</p>	<p>FSCM 58307</p>	<p>DRAWING NUMBER 30957</p>	<p>REV LTR M</p>
		<p>SCALE - NONE</p>	<p>RELEASE DATE: 4/10/02</p>	<p>SHEET 1 OF 11</p>	



# CAPACITOR SPECIFICATION

MODEL NUMBER: 30957

PARAMETER	VALUE	UNITS	Q.A.	METHOD
CAPACITANCE:	115	uF	100%	120 Hz, 23 °C
TOLERANCE:	± 5	%		
RATED VOLTAGE:	2.3	kV		
TEST VOLTAGE:	2.5	kV	100%	60 sec HIPOT
RATED ENERGY:	304.2	Joules		
RATED VOLTAGE REVERSAL:	10	%		
MAX. VOLTAGE REVERSAL:	70 (FAULT)	%		1 CYCLE
RATED PEAK CURRENT:	0.03	kA		
MAX. PEAK CURRENT (FAULT):	0.1 (FAULT)	kA		1 CYCLE
MAX. RMS CURRENT	3	Amps RMS		
MAX. OPERATING TEMP.	60	°C		
MIN. OPERATING TEMP.	-20	°C		
STORAGE TEMP:	-40 to 70	°C		
DESIGN LIFE AT RATED:	1.0E+04	Charge / Discharge cycles (5% Cap Loss)		
DC LIFE:	83.3	hours		
RELIABILITY AT LIFE:	99	%		
MAX. DISSIPATION FACTOR	1.00	%	100%	120 Hz, R.T.
MAXIMUM ESR	0.1	Ohms	100%	10 kHz, R.T.
APPROX. INDUCTANCE	200	nH	SAMPLE	STANDING WAVE
MAX. LEAKAGE CURRENT	100	uA	SAMPLE	50 °C, 2300 V, 120 sec
CASE STYLE:	DRAWN METAL CAN W/ PVC SLEEVE			
BUSHING:	2 ea FLYING LEADS			
ELECTRODE:	22 AWG WIRE W/ FASTON CONNECTOR			
CASE TERMINAL:	NONE			
DIMENSIONS:	1.91 x 2.91 x 3.75	inches		
	49 x 74 x 95	mm		
APPROXIMATE WEIGHT:	0.68	lbs		
	0.31	kg		

NOTES:

- NOTE 1: LEAK TEST: 100 % test and inspection
- NOTE 2: RSO IMPREGNANT (non-PCB)
- NOTE 3: DESIGNED TO MEET ZOLL MEDICAL SPECIFICATION 9126-0006-PS

R.T. = Room temperature, 23 ± 7 °C

	SIZE	FSCM	DRAWING NUMBER	REV LTR
	A	58307	30957	M
			SHEET	2

CASE: DRAWN METAL CAN W/ PVC SLEEVE  
 TERMINALS: 2 ea FLYING LEADS  
 ELECTRODE: ALUMINUM METALLIZED FILM  
 DIELECTRIC: MET. PPL  
 IMPREGNANT: RSO

STEP	PROCESS	INSTRUCTIONS
1.0	VERIFY PICKED PARTS TO BOM	OP-002
2.0	DEGREASE PARTS	II-004
3.0	SUBASSEMBLY	
3.1	Cut Insulation & Buswork Parts	See Assembly Piece Parts
3.2	Assemble Cover	Per Subassembly Drawing 11710-505; AI-082
3.3	Drill Bushing Cups for Flying Leads	Refer to Page 10 (This can also be performed at Step 18)
4.0	WIND PADS	AI-035; AI-092
5.0	STACK IN CLAMPS	AI-036
6.0	ARC SPRAY	AI-018 & DWG 11263-005 ZINC ONLY (FULL END SPRAY)
7.0	SOLDER TABS TO PADS IN CLAMPS	AI-028
8.0	INSULATE/WRAP	AI-002; AI-005
9.0	INSERT IN CAN	
10.0	SPOT WELD TABS TO TERMINALS	AI-048
11.0	SEAM COVERS	AI-019
11.1	FIRST ARTICLE INSPECTION	AI-047
12.0	DRY AND IMPREGNATE	II-002; 10702-005 Ok to Stack Up to 3 Layers in Tank Liners
13.0	SEAL-OFF	II-003
14.0	DEGREASE	II-004
15.0	POST-CURE	PER DRAWING 12218-003
16.0	ADD FLYING LEADS	See PAGE 10, Steps 1, 2 & 3
17.0	ACCEPTANCE TEST	SEE TEST PAGE
18.0	EPOXY FILL BUSHING CUPS (STEP 4)	See PAGE 10; AI-091
19.0	LABEL	AI-022
20.0	SLEEVE CAN	AI-090
21.0	FINAL INSPECTION	

<b>MANUFACTURING PROCESS</b>	SIZE	FSCM	DRAWING NUMBER	REV LTR
	A	58307	30957	M
			SHEET	3

<b>RATED CAPACITANCE</b>	<b>115.0</b> uF	<b>POS CAP TOLERANCE</b>	<b>5.0</b> %
<b>DESIGN CAPACITANCE</b>	<b>115.0</b> uF	<b>NEG CAP TOLERANCE</b>	<b>-5.0</b> %
<b>RECOMMENDED W/M</b>	<b>9-Inch / 6-Spindle HILTON</b>	<b>No. PARALLEL WINDINGS</b>	<b>1</b>
<b>ARBOR</b>	<b>0.625 INCHES</b>	<b>No. SERIES GROUPS</b>	<b>1</b>
<b>WINDINGS PER UNIT</b>	<b>1</b>	<b>SECTIONS PER WINDING</b>	<b>1</b>

<b>DEAD START</b>	<b>2.0</b> ±	<b>1.0</b> INCH	<b>1.0</b> ±	<b>1.0</b> TURNS
<b>ACTIVE LENGTH</b>	<b>8423</b> ±	<b>210</b> INCH	<b>ACTIVE TURNS</b>	<b>1900</b> ±
	±			±
	±			±
<b>DEAD FINISH</b>	<b>7.0</b> ±	<b>3.5</b> INCH	<b>2.0</b> ±	<b>1.0</b> TURNS

<b>DIELECTRIC LENGTH</b>	<b>8432</b> ±	<b>214.5</b> INCH	<b>FOIL LENGTH</b>	<b>8423</b> ±	<b>210.0</b> INCH
<b>EXTENDED FOIL</b>	<b>0.06</b> ±	<b>0.04</b> INCH	<b>ROLL DIAMETER</b>	<b>2.17</b> ±	<b>0.13</b> INCH
<b>EDGE MARGIN</b>	<b>0.12</b> ±	<b>0.02</b> INCH	<b>PAD THICKNESS</b>	<b>1.49</b> ±	<b>0.08</b> INCH
	±		<b>PAD WIDTH</b>	<b>2.59</b> ±	<b>0.20</b> INCH
<b>ACTIVE WIDTH</b>	<b>2.66</b> ±	<b>0.03</b> INCH			

### WINDING MATERIALS

SEQ No	MLI PART NO.	DESCRIPTION	QUANTITY
10	10581-112	FILM, MPPL, 4.8um x 75mm, 3mm EM 60-200 ohm/sq, HE	2 rls
	Note:	Steinerfilm USA and Birkelbach are approved suppliers.	
30	50057-390	ARBOR INSERT, KRAFT 0.005 x 2.95 x 2.00	1 ea
40	See Assy Piece Parts	FINISH INTERLEAF, PPL 100ga x 11.00 x 2.95	1 ea
35	50057-391	PROTECTIVE WRAP, 0.005 x 2.95 x 9.0	1 ea

**TEST: PAD DRIPOT VOLTAGE**    NA    -0, +    0.0kV    DRY CAP (PAD)    108.0 +-    5.4uF  
102.6 to    113.4 uF

**NOTES:**

- \_\_\_\_\_ METALIZED SIDE OF FILM FACES OUT ON WINDING
- \_\_\_\_\_ AT START: CUT INSIDE FILM SHORT
- \_\_\_\_\_ AT FINISH: INSERT INTERLEAF UNDERBOTH FILMS, CUT INNER FILM SHORT

DESIGN POINT = 115 uF (1030 [1051 dry]) 2% / 0%

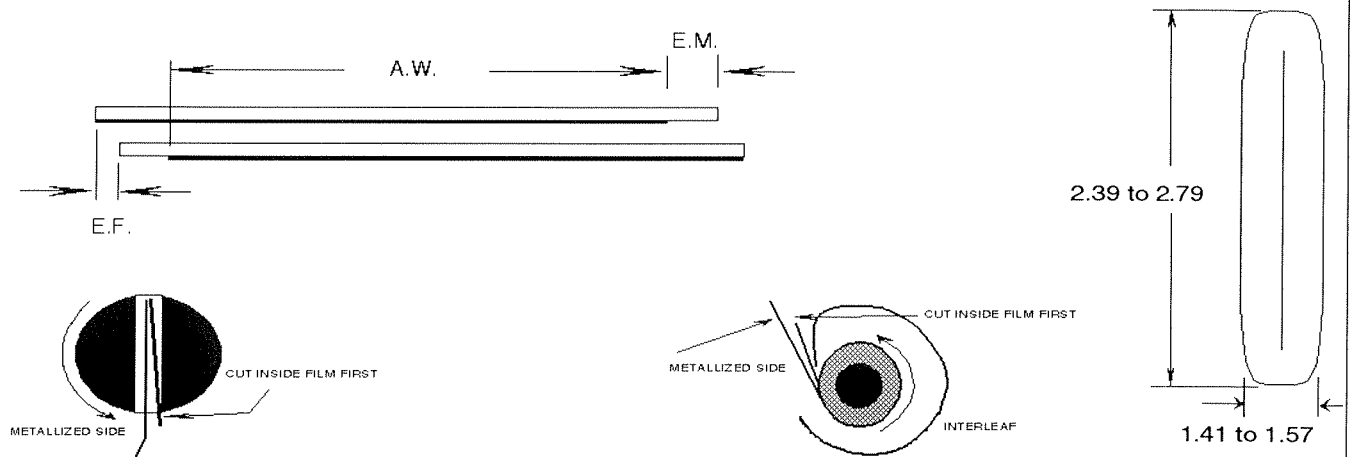

## WINDING SPECIFICATION

SIZE	FSCM	DRAWING NUMBER	REV
A	58307	30957	LTR
			M



SUPPLY ROLL LOCATIONS				
SPINDLE NUMBER	BOM SEQ No.	MATERIAL TYPE	DIAL SETTING (PSIG)	TOL +/- (PSIG)
B-1	10	MET FILM	4.1	+/- 0.5
2				
B-3	10	MET FILM	4.2	+/- 0.5
4				
5				
6				
7				
8				
9				
10				
11				
12				
13				
14				
15				
16				
FOIL-L				
FOIL-R				

RECOMMENDED PROGRAM		
LEVEL	COUNT	OUTPUT
01	1934	TURNS
02		Back up 2 turns for start
03		of next winding.
04		= 1932 Turns
05		
06		
07		
08		
09		
10		
11		
12		
13		
14		
15		
16		
17		
18		
19		
20		
21		
22		
23		
24		
25		
26		
27		
28		
29		
30		
31		
32		
33		
34		
50		
51		
52		
53		
54		
55		
56		
57		
58		
59		
60		
61		
62		
63		
64		
65		
66		
67		
68		
69		
70		

AIR PRESSURE		
GAUGE	PSIG	TOL +/-
WC		
WF		
WA		
HT		
LT		
PR		
LFF		
LFC		
RFF		
RFC		
LTC		
RTC		
TST		
AKO		

SPEEDS		
CONTROL	DIAL SETTING	TOL +/-
SPEED	750	+/- 50

SUGGESTED SPACERS	
DIELECTRIC	
LEFT FOIL	
RIGHT FOIL	

OTHER	
ARBOR	0.625
SPREADER BAR (IN/OUT)	

**8-INCH HILTON END WINDER**

**WINDING MACHINE SETUP**

SIZE	FSCM	DRAWING NUMBER	REV LTR
A	58307	30957	M
SHEET			5 B

MAKE FROM BOM SEQ No.	DESCRIPTION	LAYERS	PLACES	MATERIAL	MILS	LENGTH (in)	WIDTH (in)	TOTAL QUANTITY	
								PCS	LBS
<b>SUB ASSY</b>	<b>WINDING</b>								
30	ARBOR INSERT	1	1	KRAFT	5	2.95	2.00	1	0.001
40	INTERLEAF - FINISH	1	1	PPL	1	11.00	2.95	1	0.002
35	PROTECTIVE WRAP	1	1	KRAFT	5	9.00	2.95	1	0.006
	WINDING SEPARATOR (10915-070)	1	1	PET	30	3.1	2.5		
	BULK ITEM (RE-USEABLE)								
<b>SUB ASSY</b>	<b>INSULATION SUB ASSY</b>								
81	OUTER WRAP	1	1	PET	5	2.75	15.5	1	0.010
100	TOP/BOTTOM INSULATORS	2	2	PET	5	2.63	1.63	4	0.004
80	BOTTOM TAB INSULATOR (see note 5)	1	1	PET	5	3.75	1.25	1	0.001
90	TUBE INSULATOR, TOP (.224 ID)	1	1	PET	2.5	2.25		1	
91	TUBE INSULATOR, BOTTOM (.224 ID)	1	1	PET	2.5	4.75		1	
85	TAB PROTECTOR	2	1	KRAFT	5	2.0	1.19	1	0.001
95	BOTTOM SPACER	1	1	PPL	188	2.0	1.25	1	0.022
110	END CAP, TOP, PUNCHED	1	1	PPL	20	2.72	1.75		
120	END CAP, BOTTOM	1	1	PPL	20	2.72	1.75		
<b>SUB ASSY</b>	<b>CONDUCTORS</b>								
200	TAB, TOP ELECTRODE	1	1	MILL-TINNED Cu	5	4	0.25	1	0.002
200	TAB, BOTTOM ELECTRODE	1	1	MILL-TINNED Cu	5	10	0.25	1	0.006
<b>SUB ASSY</b>	<b>COVER ASSY (NOTE 1)</b>		1						
220	COVER ASSEMBLY	1	1	11710-505				1	
	(Single lug terminals, Black/Black)								
	Drill Bushing Cups for Flying Leads								
Alt: 225	Alternate: Cover Assy w/Rolled Rivet		1	11710-507					
<b>SUB ASSY</b>	<b>FLYING LEADS (NOTE 2)</b>								
									<b>See Page 10</b>
310	CABLE ASSY, RED		1						
320	CABLE ASSY, WHITE		1						
300	EPOXY RESIN	A/R							
305	EPOXY CURING AGENT	A/R							
<b>SUB ASSY</b>	<b>CAN SLEEVE (NOTE 2)</b>		1						
440	HEAT SHRINK TUBE, 103mm DIA		1	Clear PVC	6	4.86 ± .03			
430	CAN BOTTOM INSULATOR (NOTE 3)	2	1	PET	5	2.63	1.63	2	

**NOTES:**

- 1) AFTER COVER ASSEMBLY IS COMPLETED DRILL EACH BUSHING CUP AS SHOWN (REFER TO PAGE 9 FOR HOLE ORIENTATION)
- 2) CABLE ASSY & SLEEVING INSTALLED AFTER TESTING
- 3) USE TWO DISKS OVER CAN BOTTOM WHEN SLEEVING CAN
- 4) FOR SOLDERING TO ARC SPRAY USE PN 101642
- 5) OK TO USE UP OLD EXISTING STOCK CUT TO 3.5"

**STANDARD TOLERANCES FOR INSULATION AND TABS CUT DIMENSIONS**

X.XX ± 0.03  
X.X ± 0.1

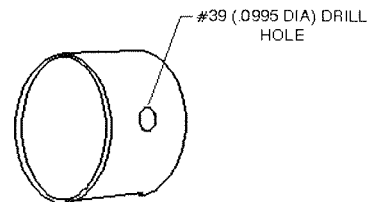

DRILLED BUSHING CUP  
(SEE NOTE 1)

<b>ASSEMBLY PIECE PARTS</b>	SIZE <b>A</b>	FSCM <b>58307</b>	DRAWING NUMBER <b>30957</b>	REV LTR <b>M</b>
				SHEET <b>6</b>

**SIDE VIEW**

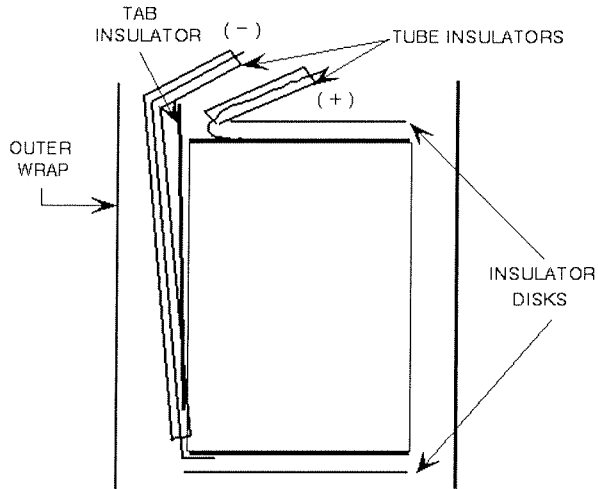

**TOP VIEW**

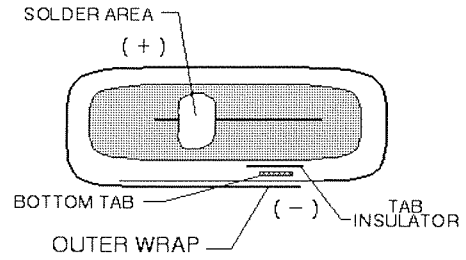

**SOLDER UNDER TABS**

SLEEVE TABS WITH PET TUBING

SPOT WELD TABS TO BUSHING TERMINALS  
ALTERNATIVE: SOLDERING

AFTER FINAL TEST:  
BUSHING CUPS GET CABLE  
ASSY & EPOXY POTTED -  
SEE PAGES 3, 6, 9, 10 & 11

**COVER**

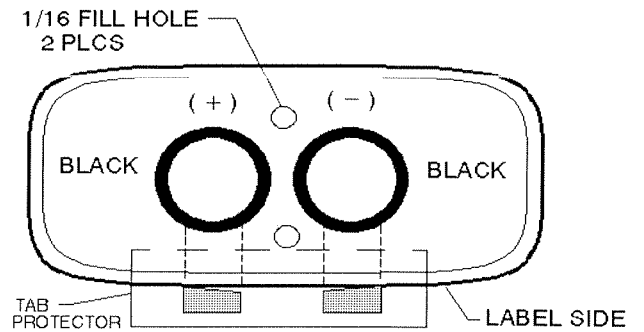

**NOTES:**

DRY CAP (UNIT): 108.0 +- 5.4 uF RANGE: 102.6 TO 113.4 uF

PRESS AT 150 PSIG PER STACK

ARC SPRAY - FULL END SPRAY, 11263-005, ZINC ONLY

SERIALIZE UNITS

**ASSEMBLY DIAGRAMS**

SIZE A	FSCM 58307	DRAWING NUMBER 30957	REV LTR M
			SHEET 7

MODEL NO.

30957

RATED CAPACITANCE

115 uF

POSITIVE TOLERANCE

5 %

NEGATIVE TOLERANCE

-5 %

RATED VOLTAGE

2.3 kV

STEP	DESCRIPTION	LIMITS		COMMENTS
		MIN	MAX	
1.0	HIPOT (R.T.)			SOFT DUMP
	VOLTAGE (kV)	2.50	2.60	
	DURATION (sec)	60	66	
2.0	TERMINAL-TO-CASE HIPOT			
	VOLTAGE (kV)	10.00	10.30	ANY LOAD
	DURATION (sec)	10	12	
3.0	MEASURE C + DF ( R.T., 120 Hz)			
	CAPACITANCE (uF)	109.3	120.8	
	DF (%)	0.25	1.00	
4.0	MEASURE C + DF ( R.T., 10 kHz)			NOTE FREQUENCY
	CAPACITANCE (uF)	NA	NA	
	DF (%)	30	70	
5.0	MAX Ipk SHOTS ( 10 SHOTS )			5 ohm LOAD
	VOLTAGE (kV)	2.50	2.60	NO HOLD
6.0	65°C LEAK TEST			NO LEAKS PERMITTED
	TEMPERATURE (°C)	60	70	
	DURATION (hrs)	8		COOL FOR > 16 hours
7.0	MEASURE C + DF ( R.T., 120 Hz)			
	CAPACITANCE (uF)	109.3	120.8	MAX CAP LOSS 0.8 uF
	DF (%)	0.25	1.00	MAX INCREASE 0.30 %
8.0	MEASURE C + DF ( R.T., 10 kHz)			NOTE FREQUENCY
	CAPACITANCE (uF)	NA	NA	
	DF (%)	30	70	

NOTES: SHORT WIRES TOGETHER AFTER TESTING  
SUPPLY TEST REPORTS WITH UNITS

LABEL INFORMATION:

CATALOG No:	30957
RATED CAP:	115.0 ± 5 % uF
VOLTAGE:	2.3 kV
IMPREGNANT:	RSO
MEASURED CAP:	XXX.X uF
SERIAL No:	XXXX-M-XX-XX
ZOLL P/N:	9126-0008 REV C

use non-PS  
Zoll dwg  
for rev level

TEST SPECIFICATION

SIZE	FSCM	DRAWING NUMBER	REV LTR
A	58307	30957	M
SHEET			8

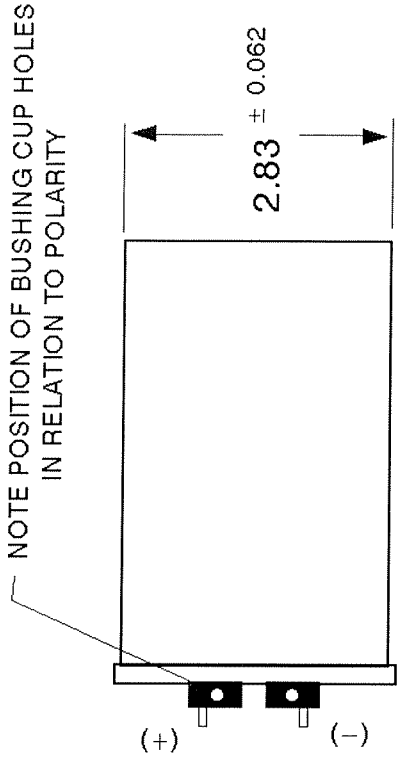
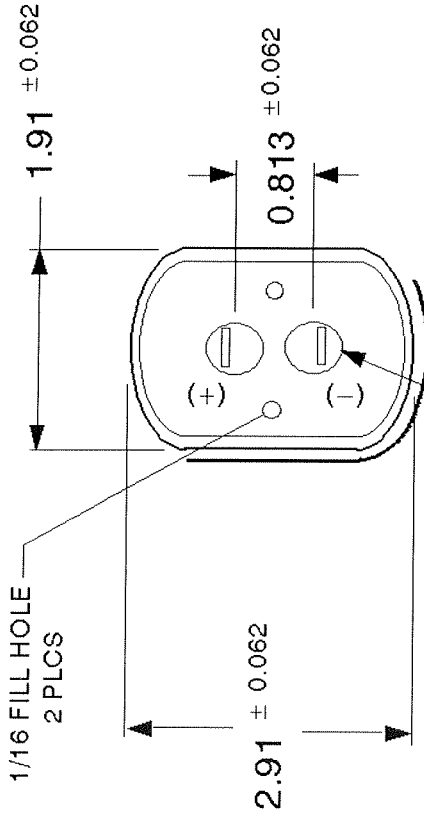

0.75 DIA  
2 PLCS

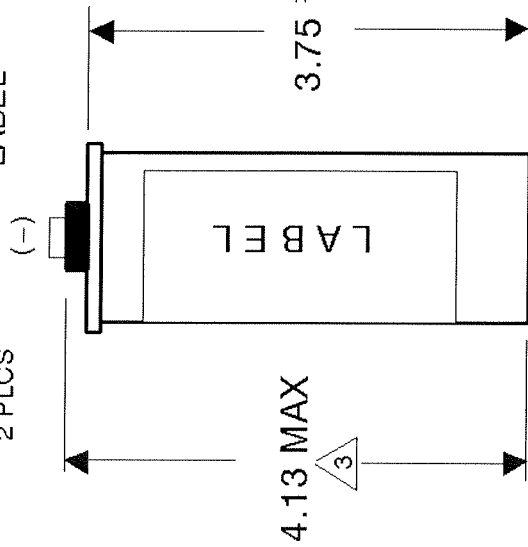

NOTES:

- 1) (-) DENOTES BOTTOM CONNECTION & OUTERMOST ELECTRODE IN WINDING
- 2) DIMENSIONS W/O SHRINK WRAP
- 3 AFTER TERMINAL & CUP POTTED
- 4) FLYING LEADS & CAN WRAP NOT SHOWN -SEE PAGES 10 & 11

<b>GENERAL ATOMICS</b> Energy Products		<b>SORRENTO ELECTRONIC</b> 4949 GREENCRAIG LANE SAN DIEGO CA. 92123	
<b>TITLE OUTLINE DRAWING</b>			
<b>CAPACITOR, MODEL 30957</b>			
<b>115.0 uF ± 5 %, 2.3 kV</b>			
SIZE	FSCM	DRAWING NUMBER	REV LTR
<b>A</b>		<b>30957</b>	<b>M</b>
SCALE	NONE	DATE	PAGE 9 OF 11
DO NOT SCALE DRAWING UNLESS OTHERWISE SPECIFIED DIMENSIONS ARE IN INCHES .X ± .1 .XX ± .03 .XXX ± .010		CONTRACT NUMBER	
PROJECT MANAGER		DATE	
PROJECT ENGINEER J. B. ENNIS		PREPARED	
APPROVED		CHECKED	
CHECKED BY		ENGINEER	
DRAWN BY J. B. ENNIS		DESIGN ACTIVITY APPROVAL	
COMPONENTS		GOVERNMENT ACTIVITY APPROVAL	
NEXT ASSY	USED ON		
APPLICATION			

TOP VIEW

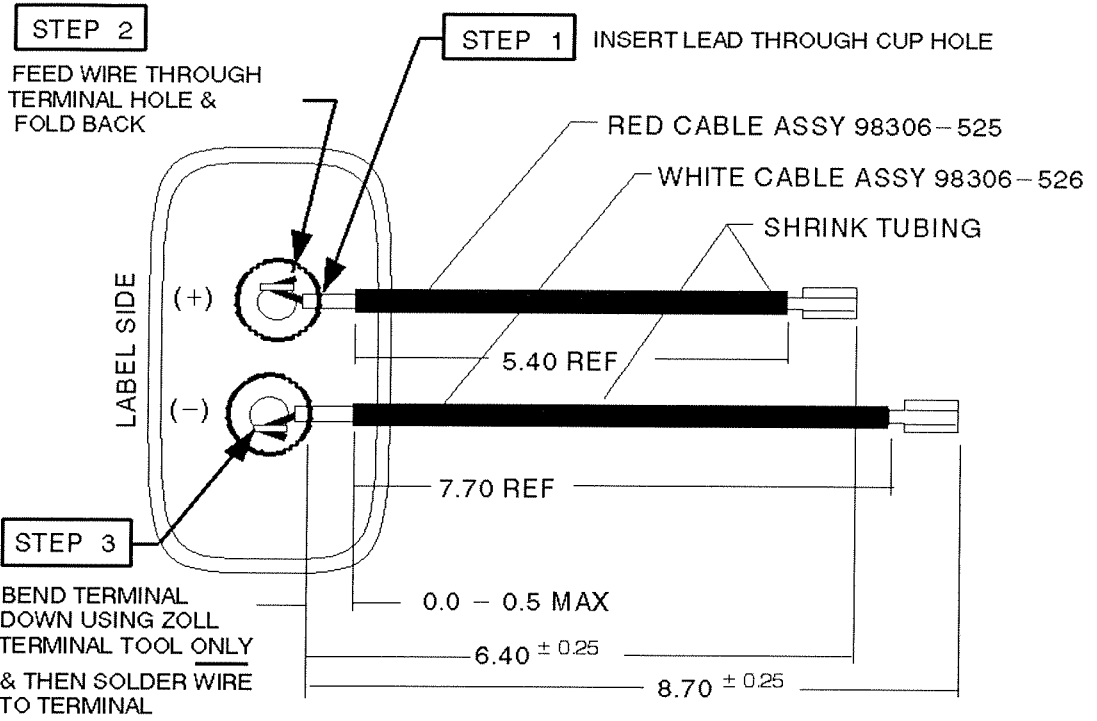

SIDE VIEW

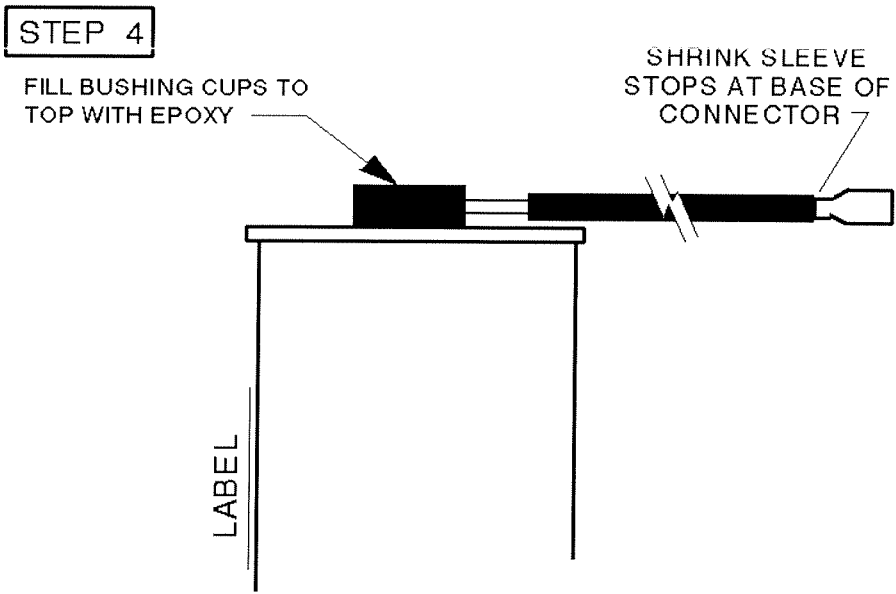

NOTE: SOLDERING USE .050" DIA SOLDER & FLUX SHIELD

FOLLOW STEPS FOR LEAD ATTACHMENT & POTTING

# FLYING LEADS

DETAIL

SIZE A	FSCM 58307	DRAWING NUMBER 30957	REV LTR M
SCALE: NONE		SHEET 10	

NOTE:  
FLYING LEADS NOT SHOWN

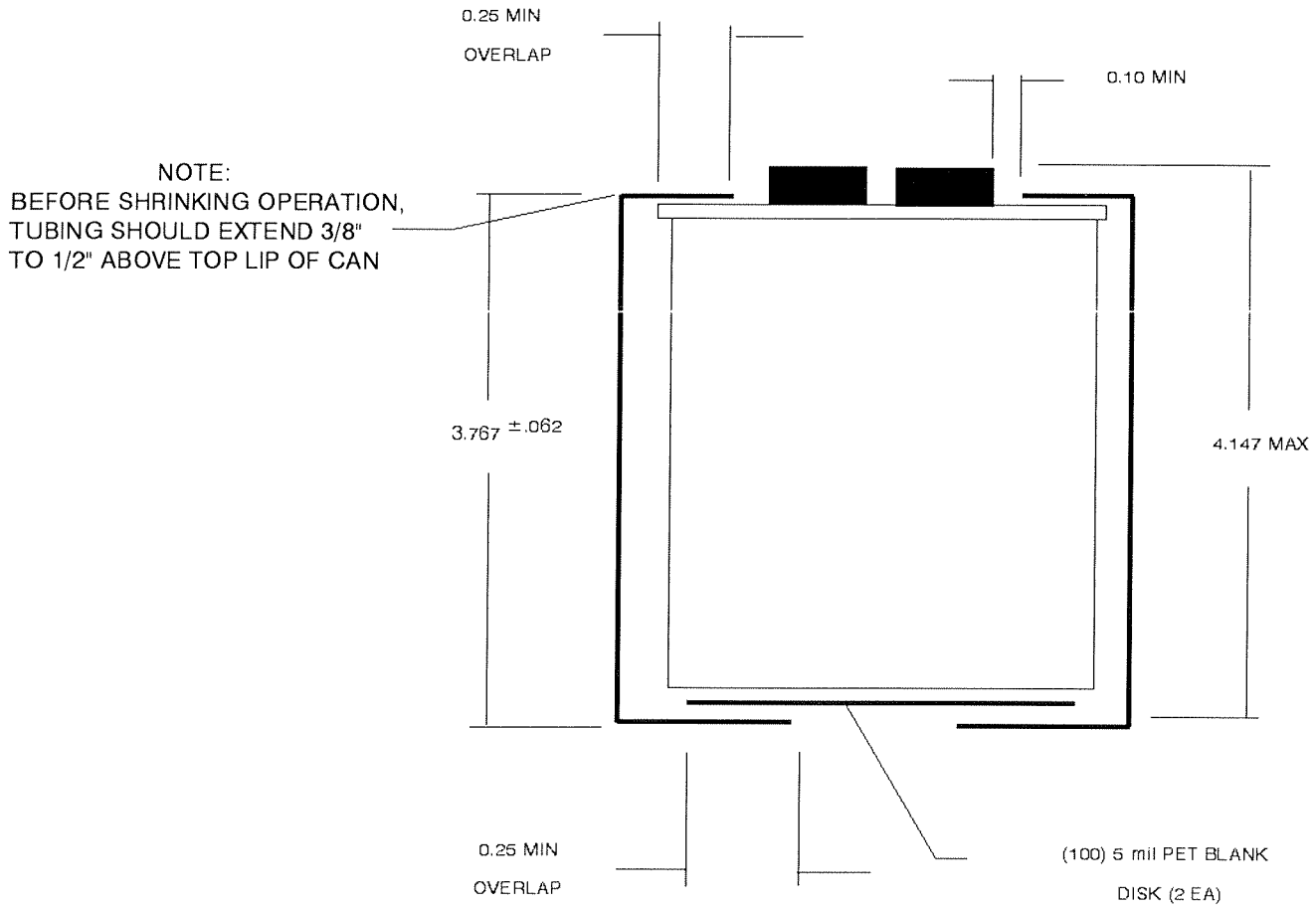
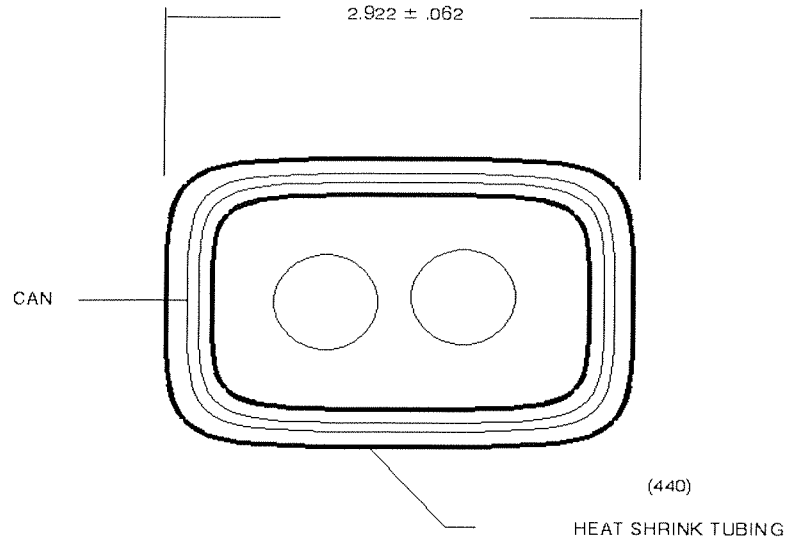

# CAN SLEEVE DETAIL

SIZE <b>A</b>	FSCM 58307	DRAWING NUMBER 30957	REV L TR <b>M</b>
SCALE: NONE		SHEET 11	